



Loving music

Statement V2

User manual



Pic. similar

User manual

Dear **Clearaudio** customer,

Congratulations on your purchase of the *Statement V2* turntable.

You have purchased a state-of-the-art turntable, the *Statement V2*, a world class product from **Clearaudio electronic GmbH**.

The special resonance-optimised construction, the external motor-unit and the patented **Clearaudio** - *CMB*-bearing-technology guarantees absolute speed stability, pure pleasure in listening and reproduction absolutely faithful to the original.

Thank you very much your confidence.

Please read this user manual carefully to ensure that your *Statement V2* turntable is correctly installed ready to take you to a new dimension of music reproduction.

We hope you will enjoy your new **Clearaudio** *Statement V2* turntable.

Clearaudio electronic GmbH

Please read the warning before connecting your *Statement V2* turntable to the mains supply.



Safety instructions

1. General information

Check the turntable for any damage before using it. Do not connect the turntable if damaged!

Never connect the turntable if it has been dropped or gotten wet, contact your dealer to have the turntable checked.

Never expose the turntable to rain or moisture.

Never touch the power cord of the device with wet hands.

Regular visual inspections for defective insulation on the connection cable are also recommended for your own safety. A damaged cable should be replaced immediately by a specialist!

Never pull on the power cord to unplug the device. Always pull directly on the plug!

The inside of the turntable is maintenance free. Never open the case or attempt to repair the unit yourself, since this can lead to loss of warranty!

We recommend disconnecting the power supply from the mains if you do not operate the device for a longer period of time.

The turntable does not feature an automatic shut-off mechanism.

Therefore, as soon as the stylus has reached the run-out groove, engage the tonearm lift and switch the turntable off.

Not suitable for children! Scope of delivery may contain small parts that can be swallowed.

2. Intended use

The *Statement* is a turntable for playing records.

The intended use of the *Statement* in accordance with the information provided in the user manual only.

The power supply may only be operated with maximum permissible connection values according to the technical data. Any other use or modification of this product is not intended.

3. Location of installation

Avoid locations with direct sunlight, temperature fluctuations and high humidity.

Likewise, avoid placing electronic devices near heaters, heat lamps, or other devices that produce heat.

The device is designed for operation at room temperature.

No objects with an open flame may be placed on or near the device (burning candles or similar).

4. Overload

The product is designed to comply with all necessary safety regulations. However, you should not leave the device unattended under extreme loads.

5. Maintenance

Never use aggressive cleaning detergent.

Do not use dry cloths for cleaning as this generates static electricity. Suitable cleaning and care products from **Clearaudio** are available from www.analogshop.de or from specialist retailers.

The bearing of the turntable platter can be lubricated every 2 years with the oil provided. Put 1 or 2 drops of the oil into the bearing for lubrication.

6. Health information

Permanently high volume can lead to various types of hearing damage. Use high volume responsibly!

IMPORTANT!

Before it is fully assembled there are strong magnetic fields around the main bearing, these could interfere with heart pacemakers and so the Statement V2 should not be setup by anyone with a pacemaker. The *Statement V2* turntable is extremely heavy and should not be assembled by anyone with back problems.

7. Service

The *Statement* turntable should be repaired during the guarantee period by the manufacturer only, otherwise the warranty claim expires. All **Clearaudio** products should only be serviced by specialist retailers.

If, despite the high production standard, a service is necessary, the *Statement* turntable must be send to **Clearaudio** through your dealer.

8. Transport

Use the original packing material for further transportation of the *Statement* turntable, otherwise serious damage could occur.

Be sure to pack the device exactly as it was shipped.
Safe transport is only guaranteed in the original packaging.

Proceed in reverse as described for assembly when packing.

Always remove the turntable platter and replace the foam securing the sub-platter and cover the bearing with tape as well. Otherwise serious damage can occur.

Remove also the pulley from the motor axle to avoid any damage during transport.

Clearaudio assumes no liability for any damage that may occur due to incorrect packing.

9. Disposal



Do not dispose this product together with other waste.
WEEE Reg. No.: DE26004446

10. CE Marking



This electronic product corresponds to the applicable guidelines for obtaining the CE mark.



Contents

1. Packaging overview	4 - 5
2. Construction overview	6
3. Setup and operation	7 - 15
4. Motor adjustment	16
5. Troubleshooting	17
6. Technical data	18
Warranty information	19 - 20

1. Packaging overview

The *Statement V2* turntable is packed and delivered on either a Euro pallet or two half size Euro pallets. The Packing is specially made for the *Statement V2* turntable and should be retained for any repacking.

Please note:

The *Statement V2* turntable is very heavy and will require at least two people to unpack and setup.

Attention / Warning:

IMPORTANT!

Before it is fully assembled there are strong magnetic fields around the main bearing, these could interfere with heart pacemakers and so the *Statement V2* should not be setup by anyone with a pacemaker. The *Statement V2* turntable is extremely heavy and should not be assembled by anyone with back problems.

The two wooden boxes contain the turntable stand and the pendulum weights, as well as five (5) separately packed cartons containing all other parts (e.g. massive metal cross, acrylic chassis, bearings etc).

Please check the accessories contents according to the following list before you setup the turntable.

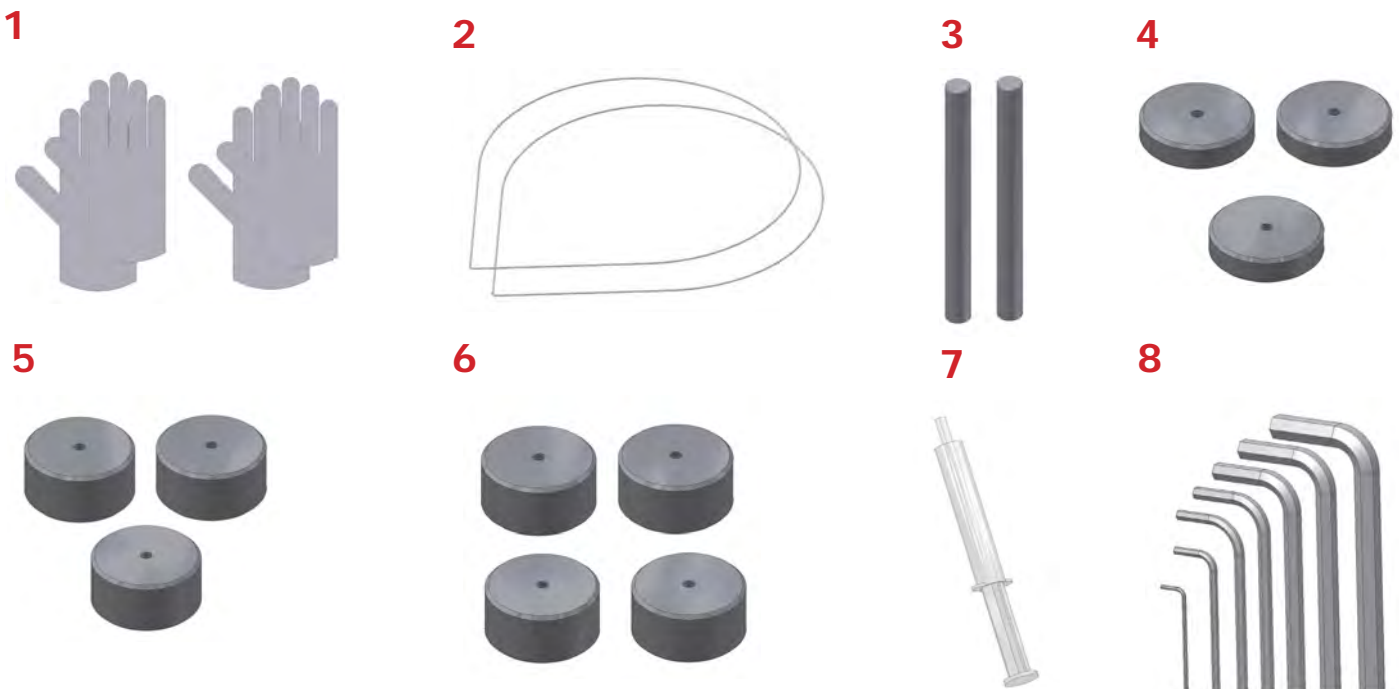

1.	Two pairs of white gloves	5.	Three bases as counter weights (40mm)
2.	Two belts	6.	Four bases as flat pads
3.	Tool for adjustment of stainless steel discs (pendulum weight)	7.	Polishing paste
4.	Three bases as counter weights (20mm)	8.	A set of hex wrenches

User manual

9



10



11



12



13



9.	Bearing oil	13.	Bubble level gauges
10.	Acrylic cleaner	14.	Not shown: Two wooden blocks
11.	Screwdriver	15.	Not shown: User manual
12.	Statement clamp	16.	Not shown: Warranty card, Clearaudio certificate card (QCQ)

2. Construction overview

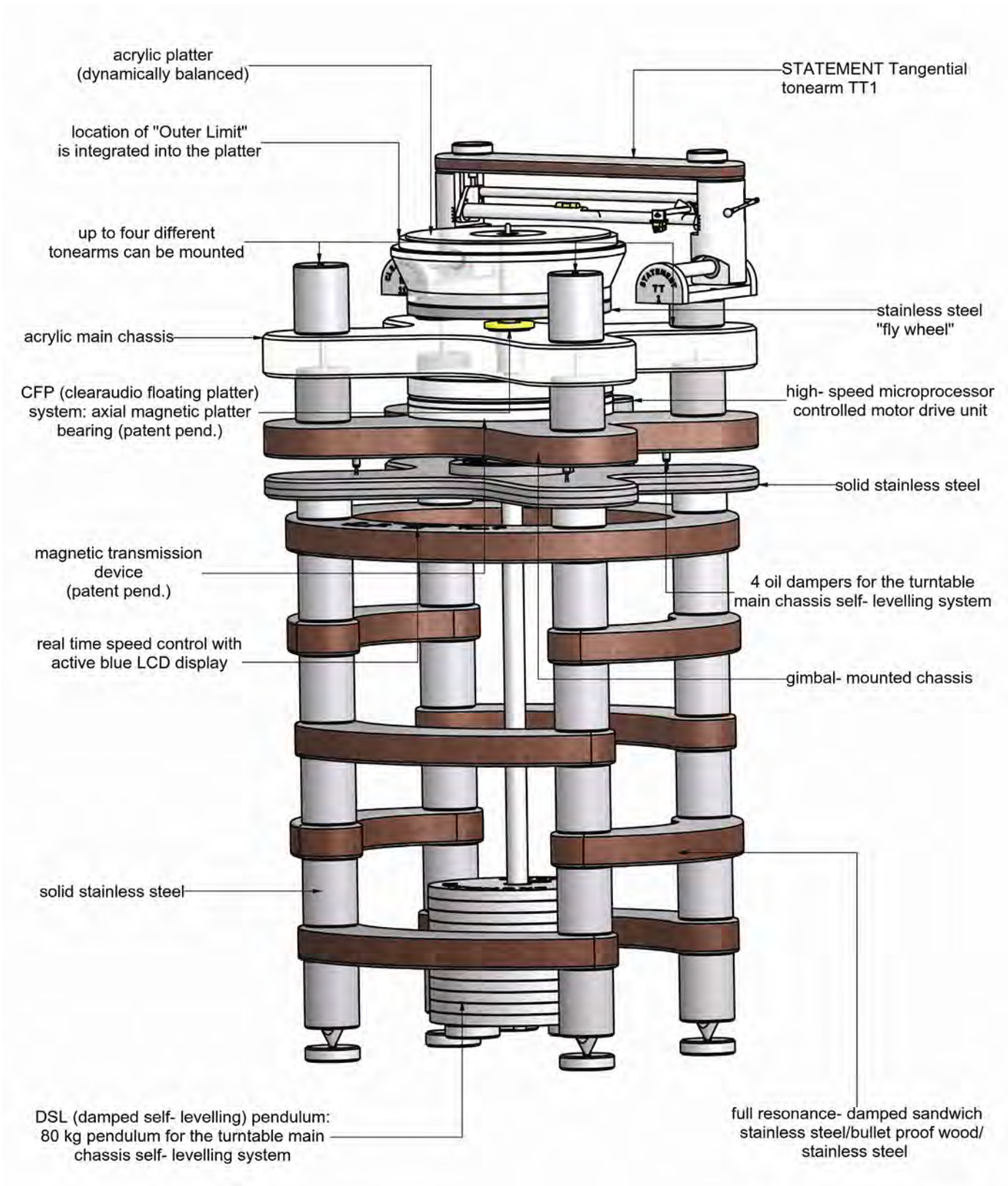

Pic. 1: Construction overview

3. Set up and operation

1. Select the position in which you will use the *Statement V2* turntable. Place the *Statement V2* turntable base in this position on the four supplied feet.



Pic. 2: Placing the *Statement*



Pic. 3: Placing the *Statement*

2. Place the two wooden blocks beneath the *Statement V2* base as shown.

IMPORTANT!

Being careful not to damage the bearing spindle on top of the pendulum shaft, assemble the pendulum, starting by sliding a solid metal disc over the pendulum shaft so that it rests on the wooden blocks. Be sure to place a felt mat between each metal disc, building the pendulum with three solid discs at the bottom, then six half-cut-away discs, then two more solid discs, finally adding the solid disc engraved with the words **Clearaudio Statement V2**.

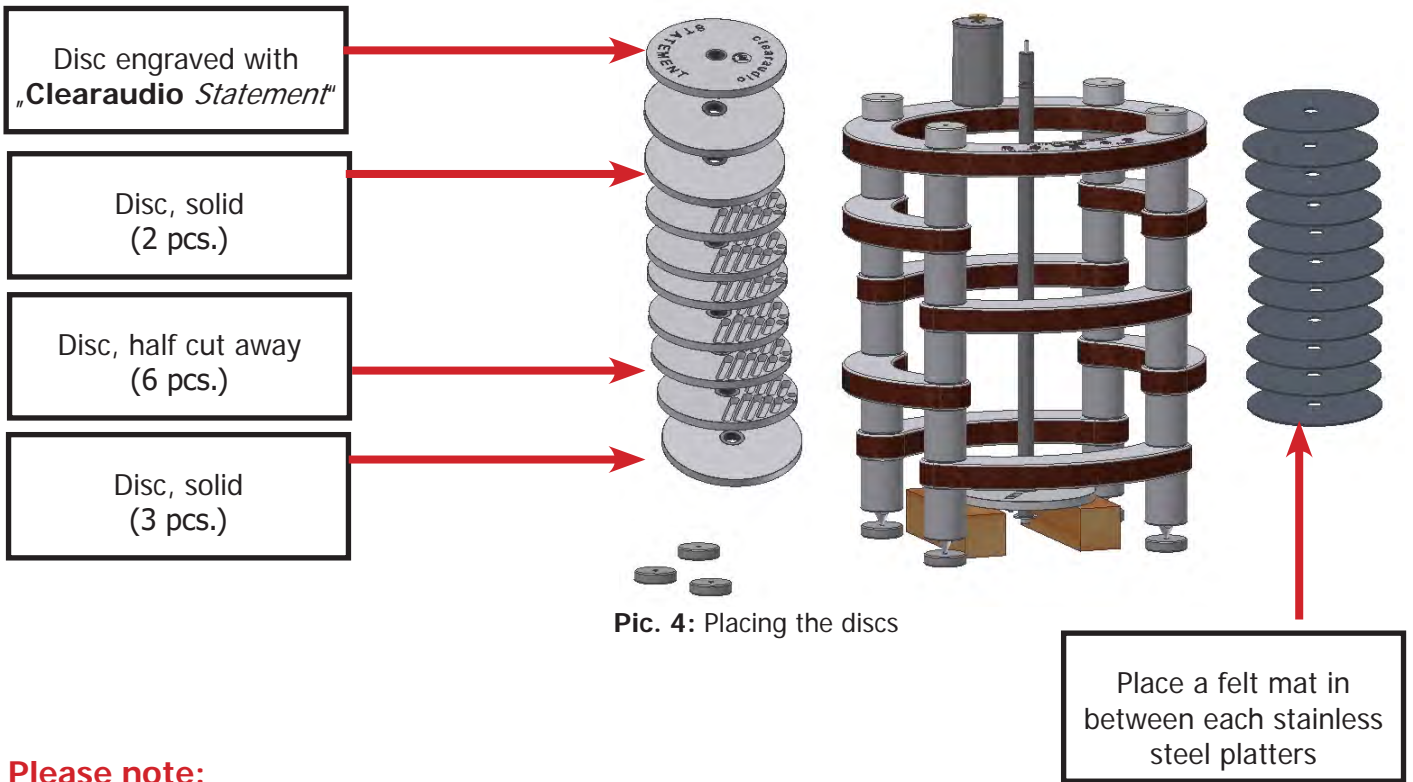

Pic. 4: Placing the discs

Please note:

If you are using the *Statement V2 TT1* tangential tonearm, position the half-cut-away discs with the cut-away section at the rear of the turntable.

3.

Place the four cork damping plates on top of the four corner pillars.

Place 4 pcs. damping plates if not assembled already from the factory

Please note:

Again, **being careful** not to damage the bearing spindle on top of the pendulum shaft, lower the stainless steel cross frame over the pendulum shaft so that it rests on the four cork damping plates.

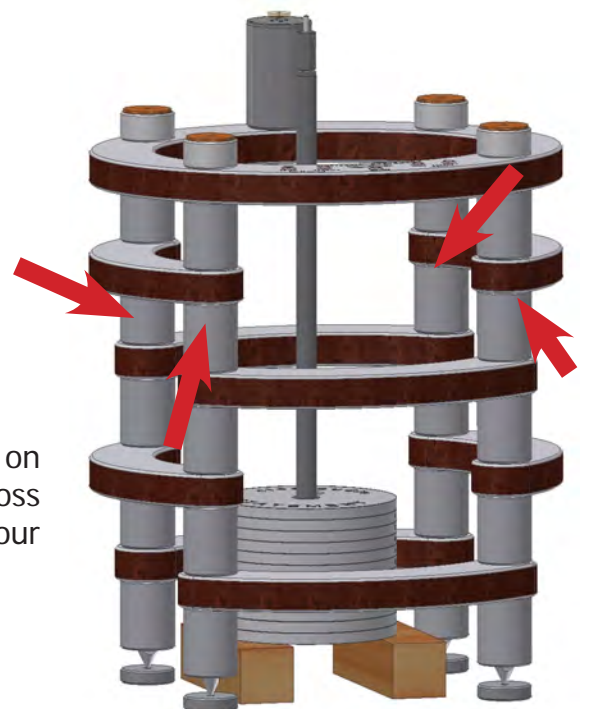

Pic. 5: Placing the cork damping plates

5.
Set the cross shaped massive metal part through the spindle onto the four cork.

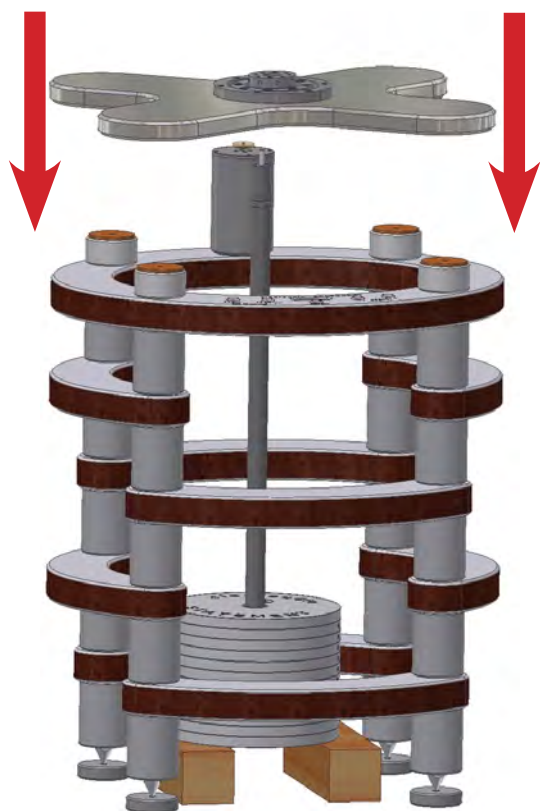

Pic. 6: Placing the metal part



Pic. 6.1: Placing the metal part

6.
Tighten the bearing to the shaft by tightening the screws in the bearing collar (8x).

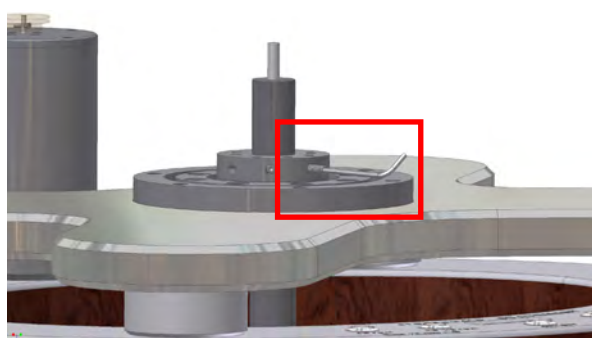

Pic. 7: Tighten the bearing

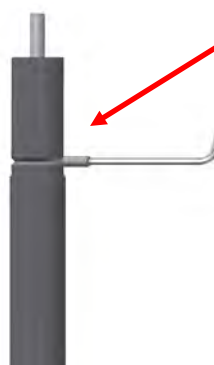

7.

Lift the pendulum shaft to align the V-shaped groove in the pendulum shaft with the locking screws in the gimbal bearing. Lock the gimbal bearing to the pendulum shaft by fully tightening the eight screws so that they locate in the groove of the pendulum shaft.

IMPORTANT!

Carefully lift the whole upper section, raising the pendulum off of the wooden blocks.

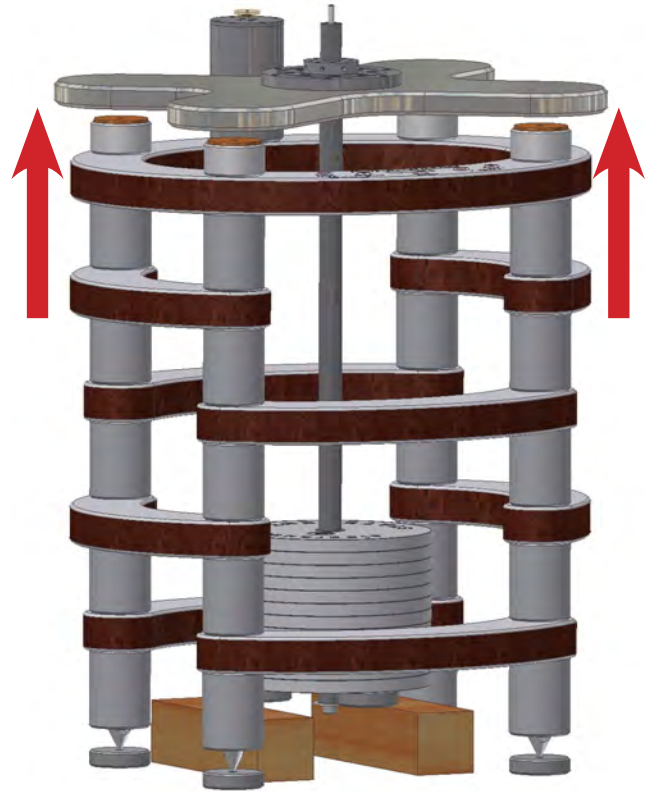

Pic. 8: Lifting the upper part

8.

Remove the wooden blocks from beneath the turntable and carefully lower the upper section back onto the four cork damping plates.

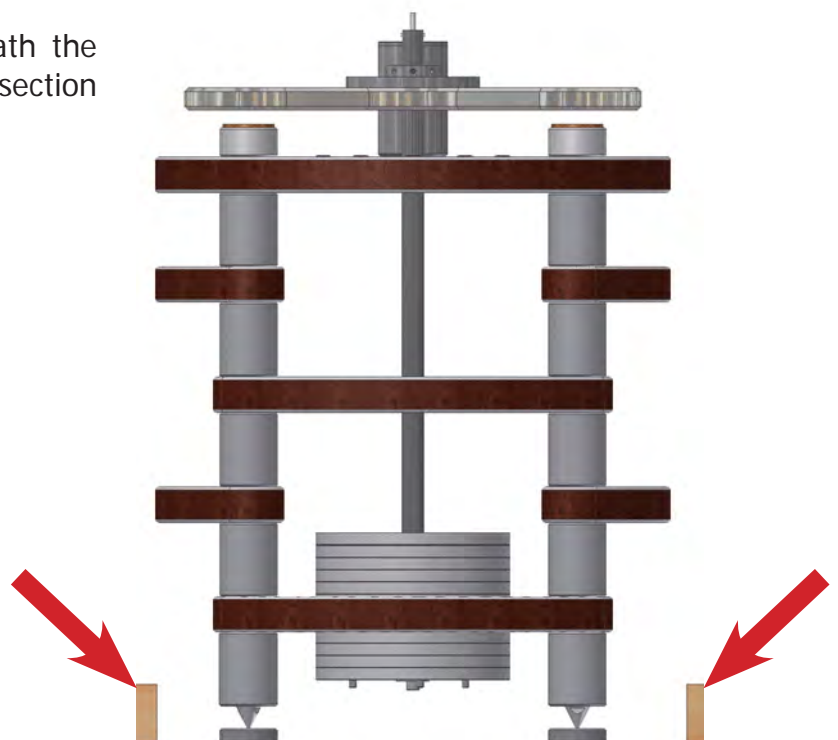

Pic. 9: Removing the wood spacers

User manual

9. Lock the floating chassis to the pendulum shaft by fully tightening the eight screws.

IMPORTANT!

Being careful not to damage the bearing spindle on top of the pendulum shaft, lower the main floating chassis over the top of the pendulum shaft.

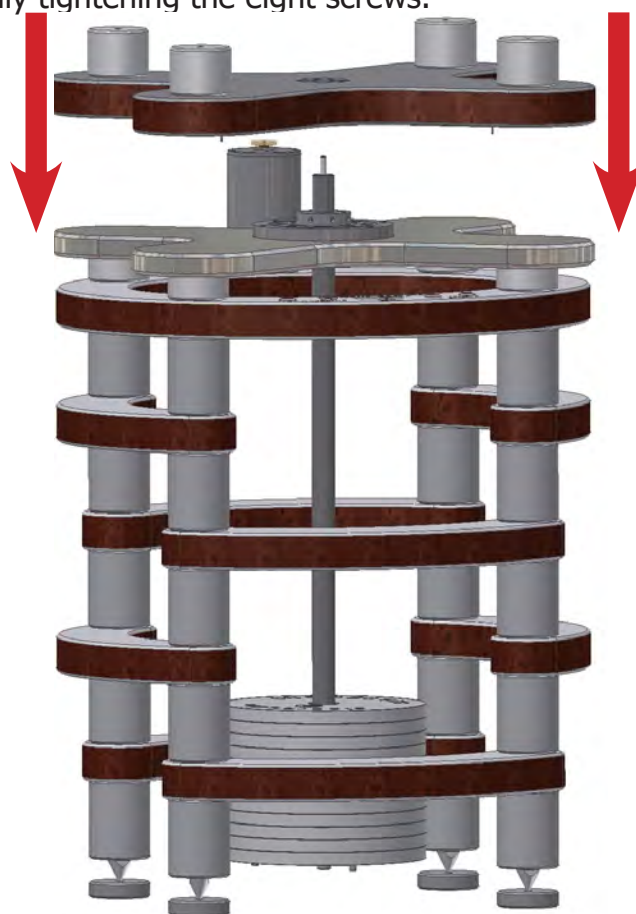

Pic. 10 : Removing the wood spacers

10. Apply 3 to 4 drops of the **Clearaudio Synthetic Bearing Oil** (also available at www.analogshop.de Art. No. AC068) to the bearing spindle.

Please apply 3 to 4 drps to the bearing spindle

Lock the 8 screws

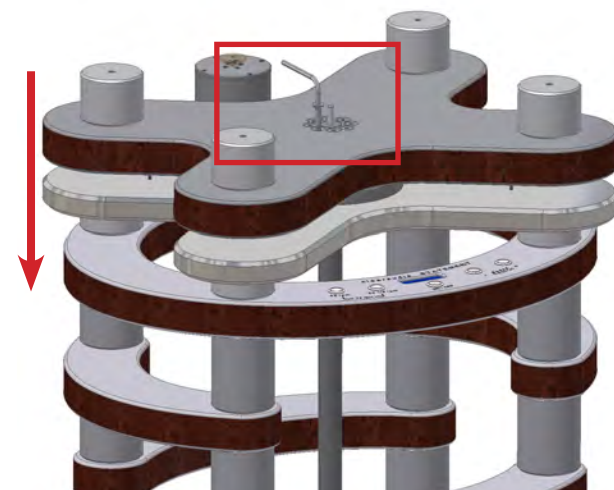
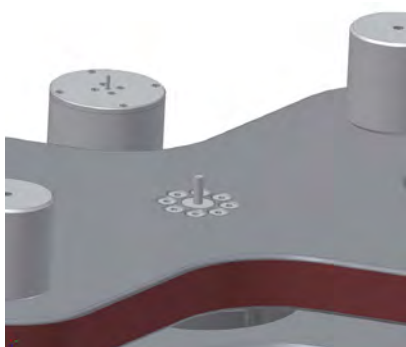

Pic. 11: Tighten the bearing screws

11.

Place the lower drive bearing housing over the bearing spindle.

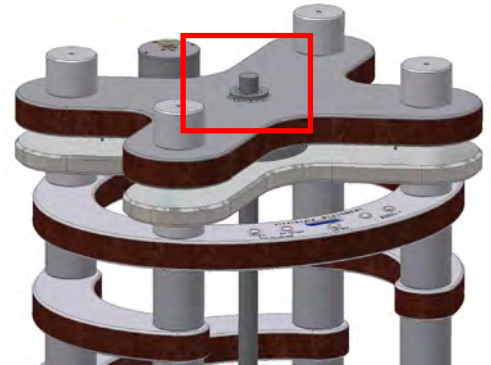

Pic. 12: Placing the lower bearing house

12.

Place the lower magnetic drive platter over the bearing housing making sure that the ring of magnets faces upwards.

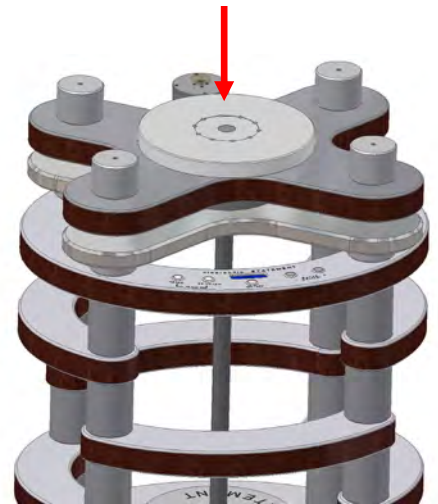

Pic. 13: Placing the lower magnetic drive platter

13.

For the next step, please apply 3 to 4 drops of the **Clearaudio Synthetic Bearing Oil** also onto the main bearing spindle.

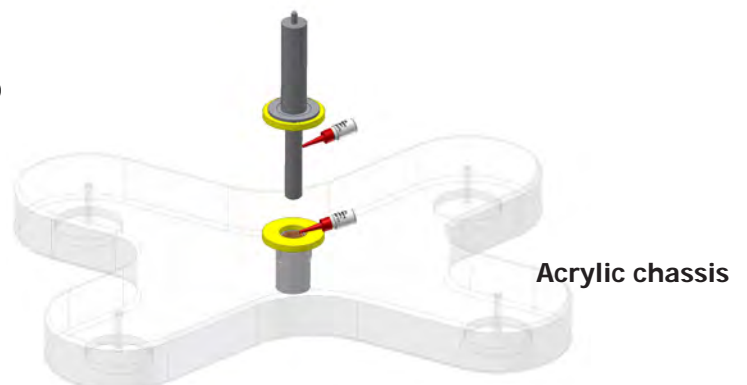

Pic. 14: Oiling the main bearing spindle

- 14.**
Making sure that the circular cut-outs in the corners of the acrylic chassis are on the underside.
Carefully (!) insert the bearing spindle into the bearing sleeve in the acrylic chassis.

IMPORTANT!

Be careful not to allow the magnets to snatch the bearing as you insert it.

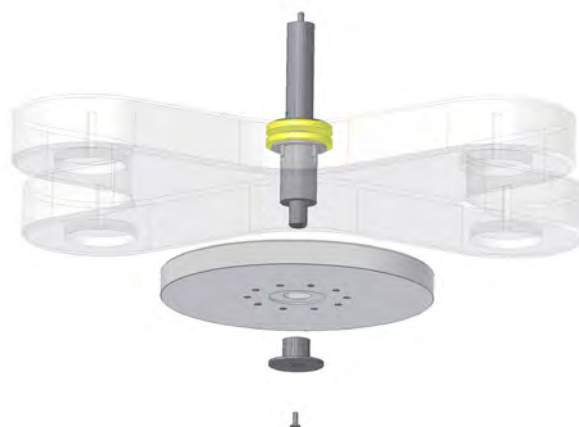

Pic. 15: To insert the bearing spindle into the bearing sleeve

- 15.**
Attach the upper drive platter to the bottom of the main bearing spindle by screwing the bottom cap very tightly to the bottom of the main bearing.
Make sure that the ring of magnets faces down.

IMPORTANT!

Gently push the upper magnetic drive platter upwards against the acrylic chassis to ensure that the platter fully sits in the bearing.

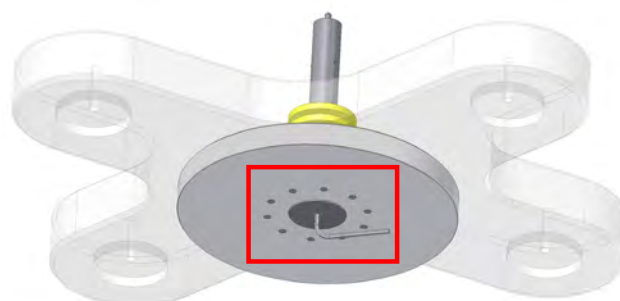

Pic. 16: To attach the upper drive platter to the bottom of the main bearing spindle

16.

Lower the acrylic chassis onto the four pillars at the corners of the floating chassis so that the circular cut-outs sit over the pillars.

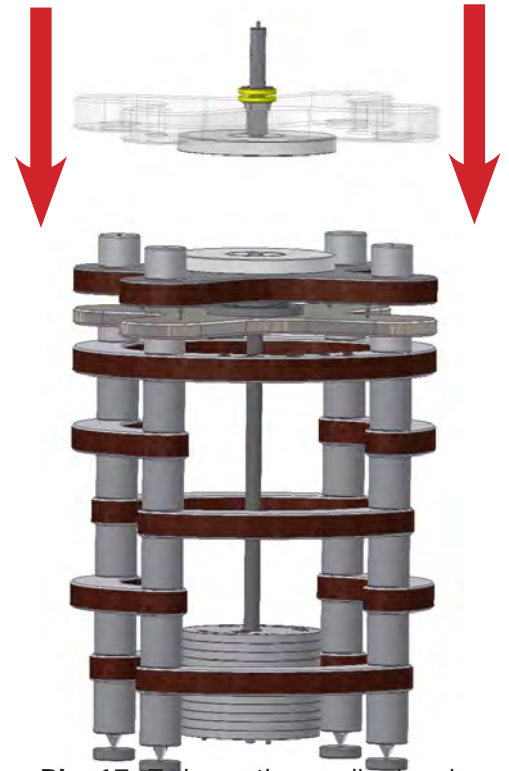

Pic. 17: To lower the acrylic chassis

17.

Firmly screw the four stainless steel arm bases through the acrylic chassis into the four pillars of the floating chassis.

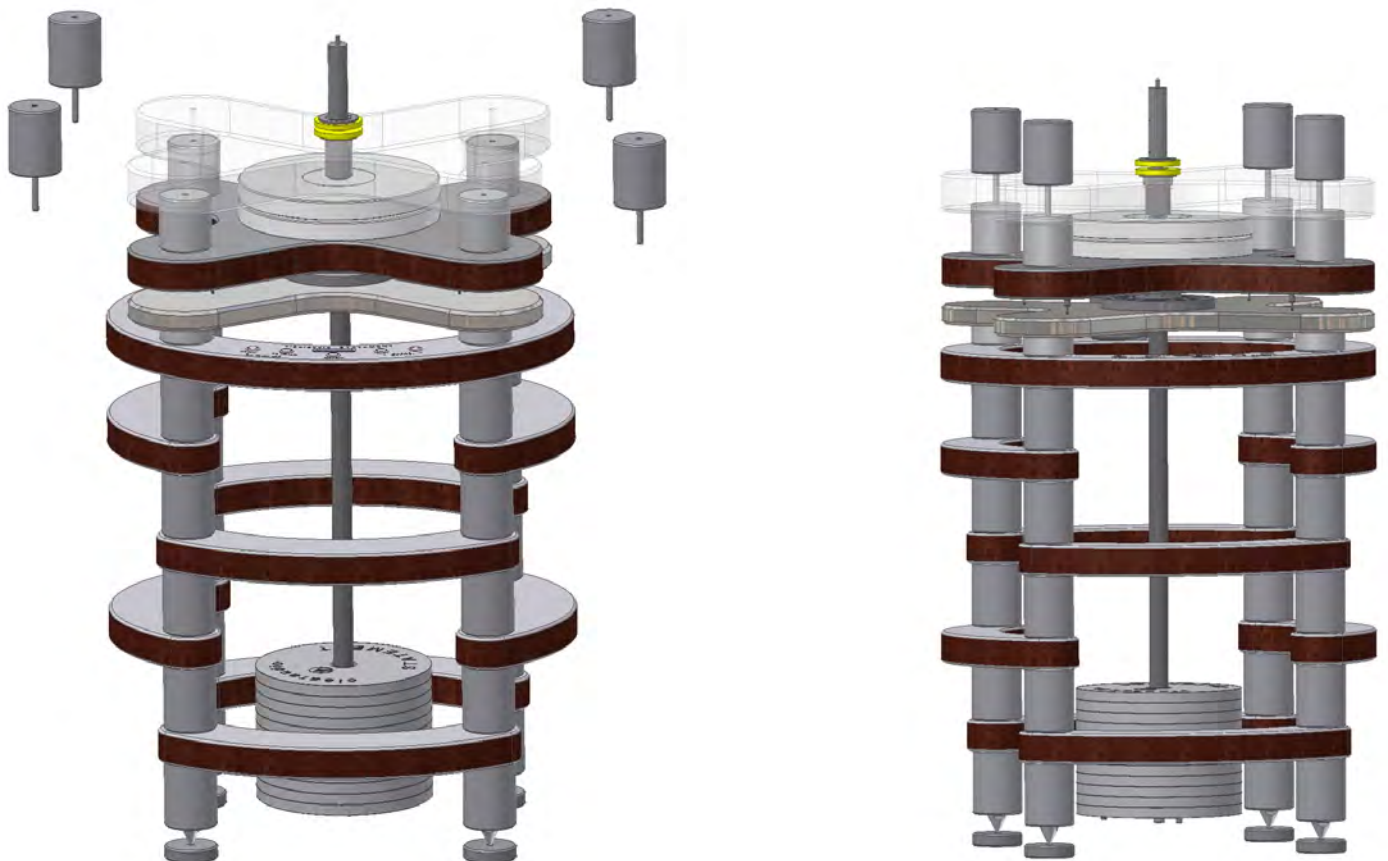

Pic. 18: Setting the arm bases

User manual

18.
Lower first the metal flywheel over the main bearing.

In the next step lower the main platter on top of the metal flywheel, making sure that the dot on the top of the bearing and the platter are aligned.



Pic. 19: Setting the platters



Pic. 20: Finished set up

4. Motor adjustment

1. Push the motor pulley over the motor spindle and lock in place by gently tightening the three screws in the side of the pulley. (If not already factory adjusted)



Pic. 21: Setting the motor pulley

2. Place the drive belt first around the lower drive platter and then around the motor pulley.

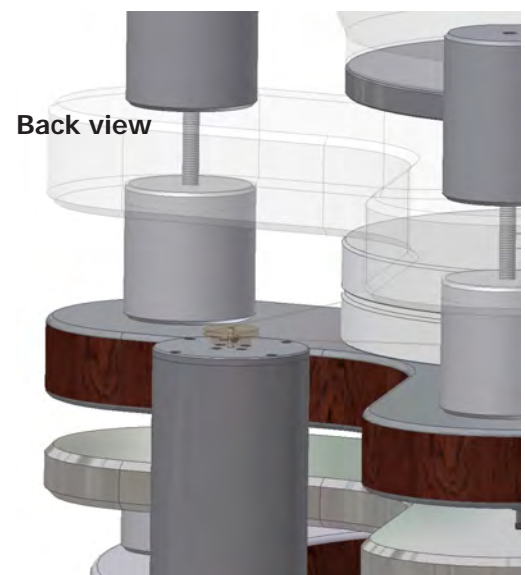

Pic. 22: Placing the drive belt

3. Plug the supplied *Statement V2* power supply first into the back of the motor, and finally into the mains supply.
4. To assembly the tonearm please refer to the instruction manual of the manufacturer.

The setup of your *Statement V2* turntable is now complete!

Clearaudio wish you al lot of pleasure and musical enjoyment with your *Statement V2*.



5. Troubleshooting

If you have a problem with your *Statement* turntable, first check the possible causes to rule out incorrect operation.

If the error persists, please contact your dealer!

Never try to open the device and/or repair it yourself, this will void the warranty!

Error	Cause	Measure
Device does not work	Is the power cord plugged in?	Check the connection.
No sound	The tonearm and phono stage are not properly connected.	Check the cable connection between the tonearm and the phono stage.
	Is the amp turned on?	Check the power supply to the amplifier.
	The volume on the amplifier/loudspeaker is set too low or on „mute“.	Check the volume settings.
	Is the cartridge protective cap still attached?	Remove the cartridge's protective cap.
	Is the tonearm in the raised position?	Lower the tonearm into the lead-in groove.
	Is the stylus damaged?	Check the stylus and have the cartridge checked by a specialist if necessary.
Bad sound / noise	Is the record or the stylus dirty or damaged?	Clean the record / or the cartridge. Clearaudio offers many helpful accessories for care and cleaning. In the event of damage, we recommend an assessment by a specialist and, if necessary, an exchange.
	Is the cartridge properly mounted into the tonearm?	Check the installation using the relevant user manual and correct them if necessary.
	Has the tracking force been set too high?	Adjust the tracking force.
	Is the correct operating mode (MM / MC) set on the amplifier?	Check the settings of your phono stage.
	The pre/amp does not have enough gain.	Check the settings of your phono stage.
	Pre/amp is mismatched.	Swap the plugs of the turntable that are connected to the left and right outputs.

Needle bounces or slides across record	Is the record or the stylus dirty or damaged?	Clean the record / or the cartridge. Clearaudio offers many helpful accessories for care and cleaning. In the event of damage, we recommend an assessment by a specialist and, if necessary, an exchange.
	Has the tracking force been set too high?	Adjust the tracking force.
	Is the record deformed or scratched?	Use a record clamp or replace the record.
	Is the turntable level?	Check the alignment of the turntable and adjust if necessary.
Platter does not turn	Is the drive belt properly attached?	Check the position of the drive belt.
	Is the power cord connected properly?	Check the connection.
	No speed was selected / speed selection in position „0“/“OFF“.	Select a speed and start the turntable.
Noisy sound	Is the drive belt properly attached?	Check the position of the drive belt. Is it too loose and needs to be changed?
Humming noises	Contact problems with the signal connections (e.g. cinch plugs, adapters for extensions)	Check all connections; reduce the level on the (pre-)amplifier to a low volume for acoustic checking of gross errors.
	Metal housing acts as an antenna and catches hum.	It can be helpful for conductivity to connect the metal parts of the turntable to the ground of the (phono) preamplifier. The turntable provides a grounding terminal for this purpose. Use a sufficiently thick wire to establish the ground connection.
	The pickup pins are mixed up, not connected correctly or defective.	Check the pin assignment of the pickup.
The music doesn't sound like usual	Wrong speed selected.	Check the record for recommended speed. There are also records in LP format (30 cm) that have to be played at 45 rpm ("maxi singles") and small records in single format (17 cm) that have to be played at 33 rpm (so-called "EP's").
	The turntable is spinning too fast/too slow.	Adjust the speed according to the operating instructions.



6. Technical Data

Construction details:	Aluminium, stainless steel and bullet proof wood
Speed options:	33 1/3, 45, 78rpm
Drive unit:	<ul style="list-style-type: none">• High-torque 24V DC motor exclusively made for Clearaudio; Optical Speed Control (OSC) in real time through infrared sensor• Decoupled DC motor in chassis; resonance damping device; belt-driven• Magnetic decoupling of turntable and additional drive platter"
Bearing:	<ul style="list-style-type: none">• Clearaudio patented ceramic magnetic bearing (CMB) in main platter / upper drive platter assembly• Inverted bearing in lower drive platter
Platter:	98mm / 3.86 inch main platter, made out of synthetic material with high-density and excellent dimension stability // precision CNC machined surface, solid stainless steel sub-platter, dynamically balanced
Speed accuracy (measured):	< ±0.03%
Power consumption:	Max. consumption: 19 watts Consumption in operation: 8 watts Off mode: 0.0 watts (if main switch is in ,0` position)
Total weight:	Approx. 350kg (without tonearm and power supply)
Dimensions (W/D/H):	Approx. 27.17 x 24.41 x 52.17 inches (with TT1 tonearm)
Dimensions (W/D/H):	Approx. 690 x 620 x 1325mm (with TT1 tonearm)
Manufacturer's warranty:	10 years*

* Provided that the warranty card is correctly completed and returned to **Clearaudio**, or your product is registered online at <https://clearaudio.de/en/service/registration.php>, within 14 days of purchase.

The full, extended warranty period for the *Statement* turntable is 10 years. To receive this full **Clearaudio** warranty, you must either complete and return the relevant section of the warranty registration card to **Clearaudio**, or register your product online at <https://clearaudio.de/en/service/registration.php>, within 14 days of purchase. Otherwise only the legal warranty can be considered.

The full 10 year warranty can only be honoured if the product is returned in its original packing.

ENGLISH WARRANTY

For warranty information, contact your local **Clearaudio** distributor.

RETAIN YOUR PURCHASE RECEIPT

Your purchase receipt is your permanent record of a valuable purchase. It should be kept in a safe place to be referred to as necessary for insurance purposes or when corresponding with **Clearaudio**.

IMPORTANT

When seeking warranty service, it is the responsibility of the consumer to establish proof and date of purchase.

Your purchase receipt or invoice is adequate for such proof.

FOR U.K. ONLY

This undertaking is in addition to a consumer's statutory rights and does not affect those rights in any way.

FRANÇAIS GARANTIE

Pour des informations sur la garantie, contacter le distributeur local **Clearaudio**.

CONSERVER L'ATTESTATION D'ACHAT

L'attestation d'achat est la preuve permanente d'un achat de valeur. La conserver en lieu sûr pour s'y reporter aux fins d'obtention d'une couverture d'assurance ou dans le cadre de correspondances avec **Clearaudio**.

IMPORTANT

Pour l'obtention d'un service couvert par la garantie, il incombe au client d'établir la preuve de l'achat et d'en corroborer la date. Le reçu ou la facture constituent des preuves suffisantes.

DEUTSCH GARANTIE

Bei Garantiefragen wenden Sie sich bitte zunächst an Ihren **Clearaudio** Händler. Heben Sie Ihren Kaufbeleg gut auf.

WICHTIG!

Die Angaben auf Ihrer Quittung erlauben uns die Identifizierung Ihres Gerätes und belegen mit dem Kaufdatum die Dauer Ihrer Garantie-Ansprüche. Für Serviceleistungen benötigen wir stets die Gerätenummer. Diese finden Sie auf dem Typenschild auf der Rückseite des Gerätes oder auch in der beigefügten Garantie-Registrierkarte.

NEDERLANDS GARANTIE

Voor inlichtingen omtrent garantie dient u zich tot uw plaatselijke **Clearaudio**.

UW KWITANTIE, KASSABON E.D. BEWAREN

Uw kwitantie, kassabon e.d. vormen uw bewijs van aankoop van een waardevol artikel en dienen op een veilige plaats bewaard te worden voor evt, verwijzing bijv, in verbond met verzekering of bij correspondentie met **Clearaudio**.

BELANGRIJK

Bij een evt, beroep op de garantie is het de verantwoordelijkheid van de consument een gedateerd bewijs van aankoop te tonen. Uw kassabon of factuur zijn voldoende bewijs.

 **ITALIANO**
GARANZIA

L'apparecchio è coperto da una garanzia di buon funzionamento della durata di un anno, o del periodo previsto dalla legge, a partire dalla data di acquisto comprovata da un documento attestante il nominativo del Rivenditore e la data di vendita. La garanzia sarà prestata con la sostituzione o la riparazione gratuita delle parti difettose. Non sono coperti da garanzia difetti derivanti da uso improprio, errata installazione, manutenzione effettuata da personale non autorizzato o, comunque, da circostanze che non possano riferirsi a difetti di funzionamento dell'apparecchio. Sono inoltre esclusi dalla garanzia gli interventi inerenti l'installazione e l'allacciamento agli impianti di alimentazione. Gli apparecchi verranno riparati presso i nostri Centri di Assistenza Autorizzati. Le spese ed i rischi di trasporto sono a carico del cliente. La casa costruttrice declina ogni responsabilità per danni diretti o indiretti provocati dalla inosservanza delle prescrizioni di installazione, uso e manutenzione dettagliate nel presente manuale o per guasti dovuti ad uso continuato a fini professionali.

 **ESPAÑOL**
GARANTIA

Para obtener información acerca de la garantía póngase en contacto con su distribuidor **Clearaudio**.

GUARDE SU RECIBO DE COMPRA

Su recibo de compra es su prueba permanente de haber adquirido un aparato de valor, Este recibo deberá guardarlo en un lugar seguro y utilizarlo como referencia cuando tenga que hacer uso del seguro o se ponga en contacto con **Clearaudio**.

IMPORTANTE

Cuando solicite el servicio otorgado por la garantía el usuario tiene la responsabilidad de demostrar cuándo efectuó la compra. En este caso, su recibo de compra será la prueba apropiada.



Loving music

clearaudio electronic GmbH

Spardorfer Straße 150
91054 Erlangen
Germany

Phone /Tel.: +49 9131 40300 100

Fax: +49 9131 40300 119

www.clearaudio.de

www.analogshop.de

info@clearaudio.de



Handmade in Germany

Clearaudio Electronic accepts no liability for any misprints.

Technical specifications are subject to change or improvement without prior notice.

Product availability is as long as astock lasts.

Copies and reprints of this document, including extracts, require written consent from

Clearaudio Electronic GmbH, Germany.

2024