



Statement TT1

Loving music

User manual



User manual

Dear **Clearaudio** customer,

Thank you for your decision to purchase the patented *Statement TT1* tangential tonearm from **Clearaudio**.

Please take a moment to read this owner's manual to ensure correct set-up, to avoid any potential damage and to discover how to care for your *Statement TT1* so that it gives you many years of musical enjoyment and pleasure.

We wish you much pleasure with your new **Clearaudio** *StatementTT1* tangential tonearm.

Clearaudio electronic GmbH

Warning

Do not expose the equipment to rain or moisture.
Do not handle the mains lead with wet hands.
No naked flame sources, such as lighted candles, should be placed on the equipment.
Never insert the oil into the precision bearing as this will result in damage of bearing.
Only for use on the *Statement TT1* turntable.

Copyright

Recording and playback of any material may require consent. For further information refer to the following:

- Copyright Act 1956
- Dramatic and Musical Performers Act 1958
- Performers Protection Acts 1963 and 1972
- Any subsequent statutory enactments and orders



Contents

1. List of components	4
2. Package overview	5
3. Front and rear view of assembled <i>TT1</i> tonearm	6
4. Assembly and operation	7 - 8
5. Mounting the <i>TT1</i> tonearm on the Statement turntable	9 - 11
6. Cartridge pre-adjustment / adjustment	12-13
7. Technical data	14
8. Special notes	15
Warranty	16

1. List of components

The **Clearaudio Statement TT1** tangential tonearm is delivered in a specially designed packaging to ensure its safe transport.

Please check the contents of completeness with the help of the pictures below:

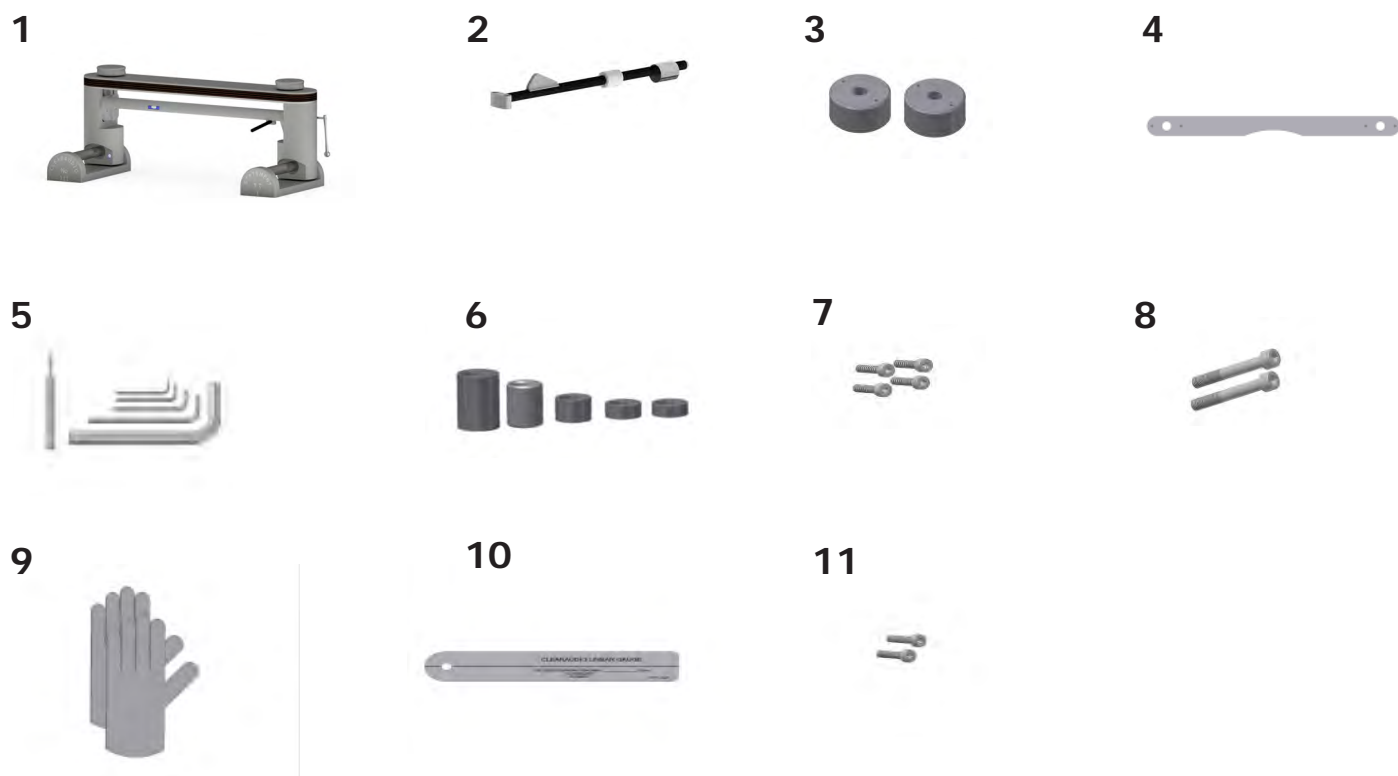

Pic. 1: Package content

1.	Tonearm chassis	7.	Hex socket headed bolts (to mount tonearm on mounting bases)
2.	Armwand, including cable	8.	2x large socket head cap screws (to attach tonearm mounting bases)
3.	Tonearm mounting base (x2)	9.	White gloves
4.	Tonearm mounting base installation gauge	10.	Cartridge alignment gauge
5.	Bag of hex keys (Allen keys)	11.	Cartridge mounting screws
6.	Main counterweights (5 pieces)	12.	User manual, Warranty card, Return delivery note (not shown)

2. Package overview

The *Statement TT1* is packed in a special foam packaging and comes almost completely assembled.



Pic. 2: Package overview

Please note:

The armwand is packed separately and need to be installed.



Pic. 3: Armwand

Additional parts, accessories and tools are also packed separately.

3. Front and rear view of assembled TT1 tonearm

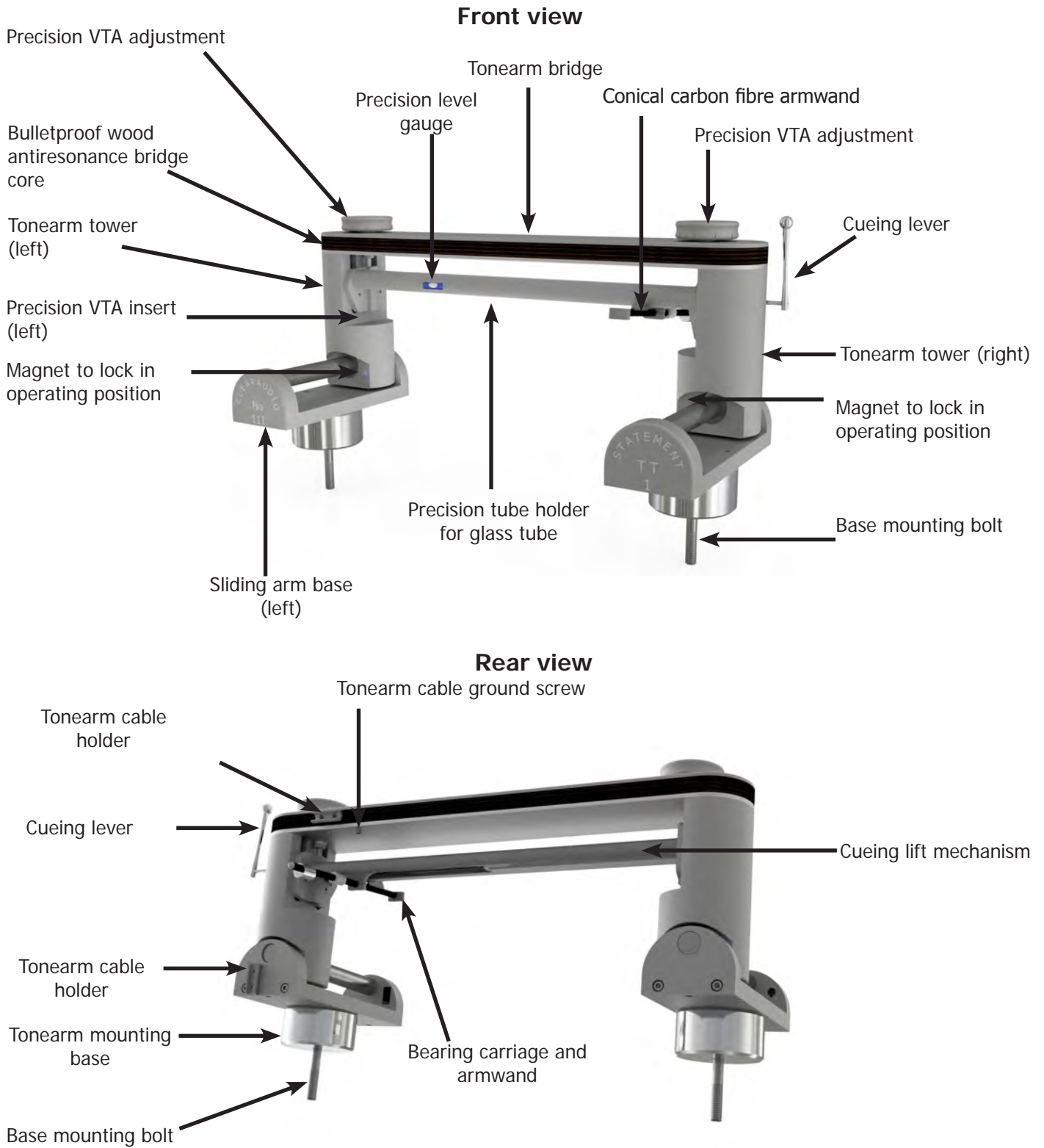

Pic. 4: Front and rear view

4. Assembly and operation

After checking that the package contents are as described (see page 4), place the parts on a clean and flat surface in preparation for setup.

Assembly and setup of the *TT1* are quite straightforward, as most parts have been factory preassembled.

Please use the white gloves provided to avoid scratches and/or fingerprints during assembly. First, install the two tonearm mounting bases (see page 4, package content No. 3) onto the *Statement* turntable. Please note, you may need to remove the existing cylinders first.

Please use only the round tonearm mounting bases provided as they are specifically height-matched for the *TT1 tonearm*.

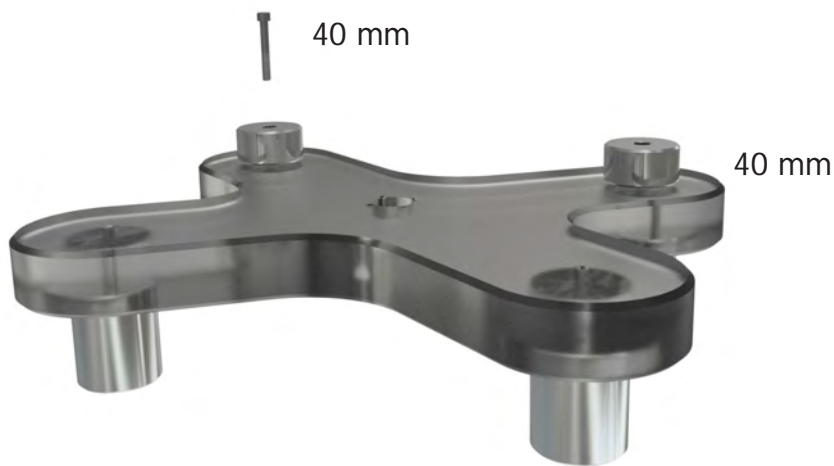

Pic. 5: Installing the stainless steel tonearm mounting bases on the *Statement* turntable

Do not tighten the base mounting bolts (see page 4 package content No. 8), you should be still able to turn the bases.

Now place the tonearm mounting base installation gauge (see picture 6 No. 4) on top of the two mounting bases (see picture 6 No. 3). Rotate the mounting bases until all four pins on the bottom of the installation gauge fit into the threads machined into the mounting bases.

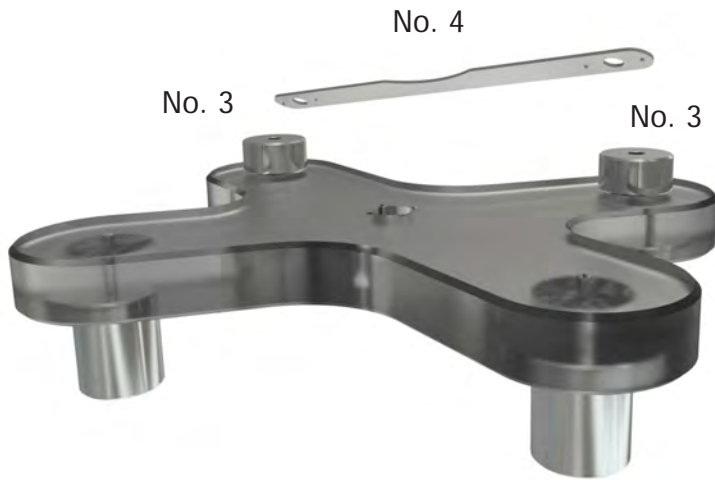

Pic. 6: Placing the installation gauge

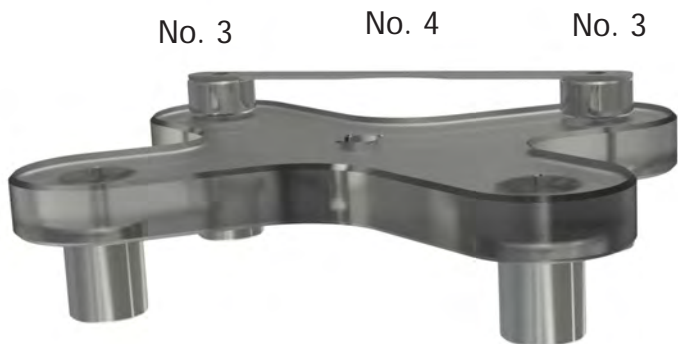

Pic. 7: Placing the installation gauge



Pic. 8: Tightening the mounting bolts

5. Mounting the *TT1* tonearm on the *Statement* turntable

Place the tonearm chassis on top of the two mounting bases. Lift it carefully, making sure that the sliding tonearm bridge is positioned to the rear of both sliding bases as shown in picture 9.

While holding it in place, insert the four socket head cap screws provided into the threaded holes in the tonearm mounting bases and tighten them.

Please note: Always hold the tonearm in place while fixing the four bolts.



Pic. 9: Placing the tonearm assembly in position



Pic. 10: Tightening the tonearm mounting bolts



Pic. 11: Finished view of the tonearm installation

Please note: You may need to readjust the levelling of the Statement turntable once you have fully completed setup of the TT77 tonearm.

Please take great care in undertaking the following steps.

Remove the rubber band which is used as transportation lock. Afterwards loosen the screws from the aluminum block and remove the second transportation lock.

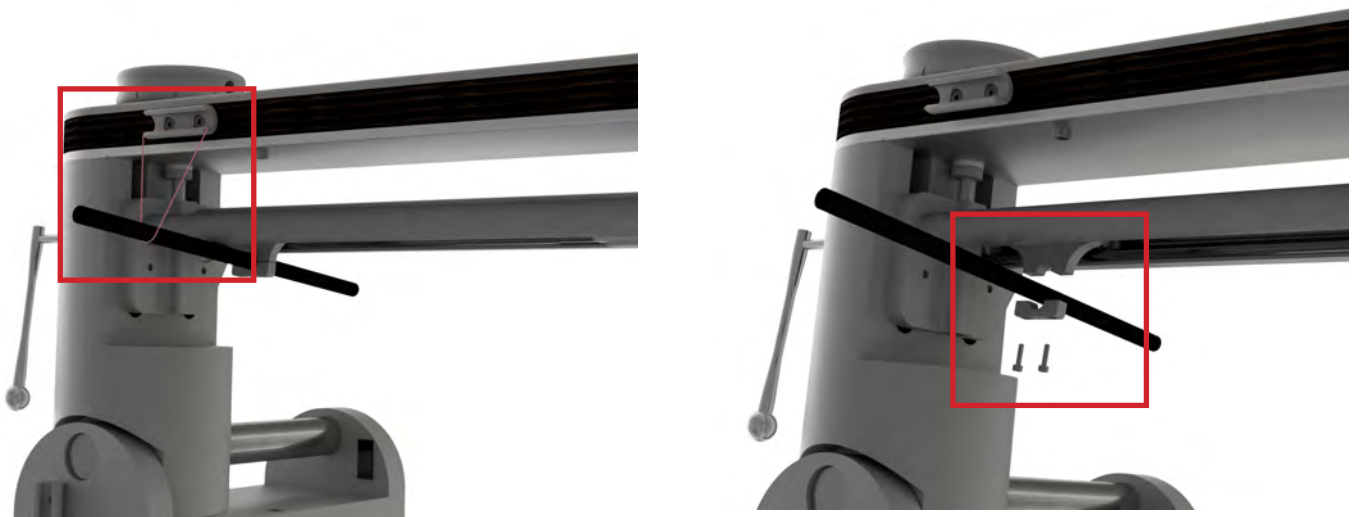

Pic. 12: Pre-mounted bearing carriage and glass tube with transportation lock

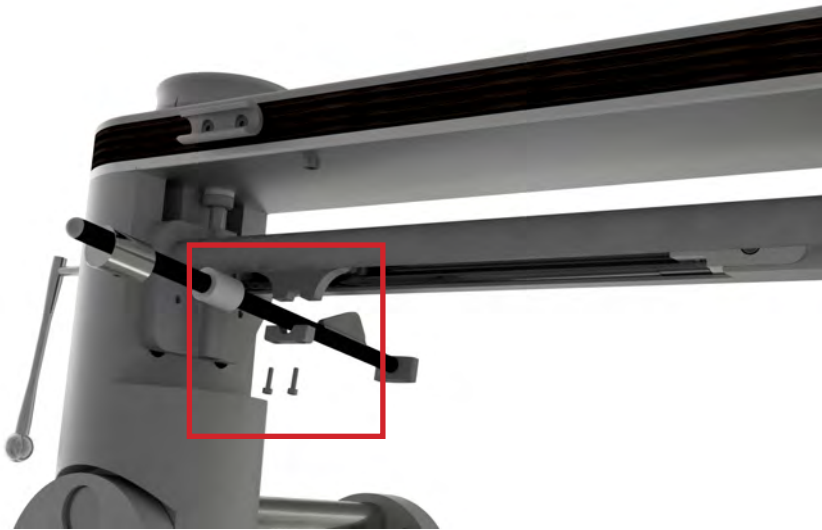

Pic. 13: Mounting of the armwand

Mount the armwand to the bearing carriage with the aluminum block and the two screws again.



Pic. 14: Mounted armwand

6. Cartridge pre-adjustment / adjustment

First mount the cartridge into the headshell using the two headshell screws provided (see page 4 content No. 11).



Pic. 15: Mounting of the cartridge

Slide the appropriate exchangeable counterweight, dependent on the used cartridge, over the back of the armwand tube and adjust the correct tracking force. Please hold the armwand carefully so you don't apply too much force to the bearings. For the best results we recommend using **Clearaudio's Weight Watcher** stylus pressure gauge (Art. No. AC094, available through www.analogshop.de)

Example:

- For the **Clearaudio Goldfinger Statement** use the 10 g counterweight
- For the **Clearaudio Titanium** use the 5 g counterweight

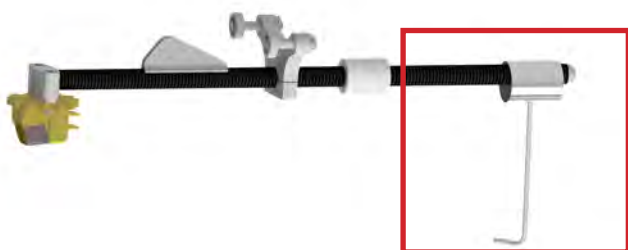

Pic. 16: Counterweight adjustment

Turn the two precision VTA adjustment knobs on top of the tonearm until both the glass tube holder and the armwand are parallel to the record surface.



Pic. 17: Cartridge pre-adjustments

Cartridge adjustment

Place a record onto the turntable platter in before starting the final adjustments.

The correct tangential adjustment is essential. To ensure the correct adjustment, use the cartridge alignment gauge (see page 4, content No. 10), which must first be placed on the spindle.

The diamond tip of the cartridge must be always aligned in the black line of the gauge. This fine adjustment can be realised by moving the armwand back or forwards. Simply lock or unlock the screw on the bottom of the carriage.



Pic. 18: Cartridge adjustment

Re-adjust the tracking force and set the cartridge Azimuth so that it is in a vertical position when viewed from the front. Make a final check of all the parameters: tonearm level, armwand level, cartridge alignment and tracking force.

Attention: Before first use or after a long period of storage, please move the cueing lift up and down approximately 4-5 times so that the oil inside can flow allowing the cueing lift to operate smoothly.

7. Technical data

Construction:	High-precision mechanical tangential extremely low friction two point linear tracking design (Patent No. PA1020060529138)
Drive:	– Strictly mechanical – Selected high precision ball bearings running in a calibrated polished glass tube
Wiring:	2 m Sixstream Super Wire terminated with RCA
Total weight:	Approx. 8.6 kg including armwand
Dimensions: (W x H x D)	Approx. 540 (incl. lift unit) x 200 x 210 Approx. 21.26 x 7.87 x 8.27 inches
Warranty:	10 years *

* Provided that the warranty card is correctly completed and returned to **Clearaudio** within 14 days of purchase.

Clearaudio electronic is not responsible for typographical errors in descriptions.
 Technical specifications subject to change or improvement without prior notice.
 Product availability is as long as stock lasts.
 Copies and reprints of this documents, including extracts, require written consent from
Clearaudio electronic GmbH; Germany



Loving music

8. Special notes

8.1 Maintenance

If the *Statement TT1* tonearm is not in use for a long period, please cover the tonearm to protect it from dust.

The glass tube can be cleaned with pure alcohol.

Please make sure that the precision dry ball bearings are not be touched, cleaned or lubricated in any way. Please only clean the glass tube.

WARNING:

Never insert the oil into the precision bearing as this will result in damage of bearing.

8.2 Transportation

Should further transportation of the *Statement TT1* tonearm be necessary, please always use the original packing material. Otherwise serious damage could occur.

8.3 Service

If any servicing or repair of a **Clearaudio** product is necessary, please first contact your dealer or distributor. Alternatively contact **Clearaudio** directly and we will advise you of your nearest service location.

PLEASE RETAIN ALL ORIGINAL PACKAGING. You will need it if this product has to be transported and/or shipped. Any further questions you may have about this product should be directed to your local dealer or direct to **Clearaudio** at:

Clearaudio electronic GmbH

Spardorfer Str. 150
91054 Erlangen
Germany

Phone: +49 9131 40300 100
Fax: +49 9131 40300 119
www.clearaudio.de
www.analogshop.de
info@clearaudio.de

To achieve the full **Clearaudio** warranty, it is necessary that you fill out and send the corresponding part of the warranty registration certificate /card back to **Clearaudio**, within two weeks after purchase. Only if the product is returned in it's original packing **Clearaudio** can provide the warranty of 10 years for the *Statment 771* tonearm .



ENGLISH

WARRANTY

For warranty information, contact your local **Clearaudio** distributor.

RETAIN YOUR PURCHASE RECEIPT

Your purchase receipt is your permanent record of a valuable purchase. It should be kept in a safe place to be referred to as necessary for insurance purposes or when corresponding with **Clearaudio**.

IMPORTANT

When seeking warranty service, it is the responsibility of the consumer to establish proof and date of purchase. Your purchase receipt or invoice is adequate for such proof.

FOR U.K. ONLY

This undertaking is in addition to a consumer's statutory rights and does not affect those rights in any way.



FRANÇAIS

GARANTIE

Pour des informations sur la garantie, contacter le distributeur local **Clearaudio**.

CONSERVER L'ATTESTATION D'ACHAT

L'attestation d'achat est la preuve permanente d'un achat de valeur. La conserver en lieu sûr pour s'y reporter aux fins d'obtention d'une couverture d'assurance ou dans le cadre de correspondances avec **Clearaudio**.

IMPORTANT

Pour l'obtention d'un service couvert par la garantie, il incombe au client d'établir la preuve de l'achat et d'en corroborer la date. Le reçu ou la facture constituent des preuves suffisantes.



DEUTSCH

GARANTIE

Bei Garantiefragen wenden Sie sich bitte zunächst an Ihren **Clearaudio** Händler. Heben Sie Ihren Kaufbeleg gut auf.

WICHTIG!

Die Angaben auf Ihrer Quittung erlauben uns die Identifizierung Ihres Gerätes und belegen mit dem Kaufdatum die Dauer Ihrer Garantie-Ansprüche. Für Serviceleistungen benötigen wir stets die Gerätenummer. Diese finden Sie auf dem Typenschild auf der Rückseite des Gerätes oder auch in der beigelegten Garantie-Registrierkarte.



NEDERLANDS

GARANTIE

Voor inlichtingen omtrent garantie dient u zich tot uw plaatselijke **Clearaudio**.

UW KWITANTIE, KASSABON E.D. BEWAREN

Uw kwitantie, kassabon e.d. vormen uw bewijs van aankoop van een waardevol artikel en dienen op een veilige plaats bewaard te worden voor evt, verwijzing bijv, in verbend met verzekering of bij correspondentie met **Clearaudio**.

BELANGRIJK

Bij een evt, beroep op de garantie is het de verantwoordelijkheid van de consument een gedateerd bewijs van aankoop te tonen. Uw kassabon of factuur zijn voldoende bewijs.

 **ITALIANO****GARANZIA**

L'apparecchio è coperto da una garanzia di buon funzionamento della durata di un anno, o del periodo previsto dalla legge, a partire dalla data di acquisto comprovata da un documento attestante il nominativo del Rivenditore e la data di vendita. La garanzia sarà prestata con la sostituzione o la riparazione gratuita delle parti difettose. Non sono coperti da garanzia difetti derivanti da uso improprio, errata installazione, manutenzione effettuata da personale non autorizzato o, comunque, da circostanze che non possano riferirsi a difetti di funzionamento dell'apparecchio. Sono inoltre esclusi dalla garanzia gli interventi inerenti l'installazione e l'allacciamento agli impianti di alimentazione.

Gli apparecchi verranno riparati presso i nostri Centri di Assistenza Autorizzati. Le spese ed i rischi di trasporto sono a carico del cliente. La casa costruttrice declina ogni responsabilità per danni diretti o indiretti provocati dalla inosservanza delle prescrizioni di installazione, uso e manutenzione dettagliate nel presente manuale o per guasti dovuti ad uso continuato a fini professionali.

 **ESPAÑOL****GARANTIA**

Para obtener información acerca de la garantía póngase en contacto con su distribuidor **Clearaudio**.

GUARDE SU RECIBO DE COMPRA

Su recibo de compra es su prueba permanente de haber adquirido un aparato de valor, Este recibo deberá guardarlo en un lugar seguro y utilizarlo como referencia cuando tenga que hacer uso del seguro o se ponga en contacto con **Clearaudio**.

IMPORTANTE

Cuando solicite el servicio otorgado por la garantía el usuario tiene la responsabilidad de demostrar cuándo efectuó la compra. En este caso, su recibo de compra será la prueba apropiada.



Loving music



Loving music

clearaudio electronic GmbH

Spardorfer Straße 150
91054 Erlangen
Germany

Phone/Tel.: +49 9131 40300 100

Fax: +49 9131 40300 119

www.clearaudio.de

www.analogshop.de

info@clearaudio.de

Handmade in Germany

(Technische Änderungen vorbehalten - Technical specification are subject to change without prior notification) 2017